

Components / Materials	W1	W2	W4	W5
Casing				AISI 316 L or similar
Bolts				A4 - 80
Bars				AISI 316 L or similar
Anchoring rings				AISI 301
Strip insert (option)				AISI 316 L / PVDF

<b>Sealing sleeve</b> <b>EPDM</b>	Temp.: -20°C up to +100°C Medium: all qualities of water, waste water, air, solids and chemical products
<b>Sealing sleeve</b> <b>NBR</b>	Temp.: -20°C up to +80°C Medium: water, gas, oil, fuel and other hydrocarbons
<b>Sealing sleeve</b> <b>FPM / FKM</b>	Temp.: -20°C up to +180°C Medium: ozone, oxygen, acids, gas, oil and fuel (only with strip insert)

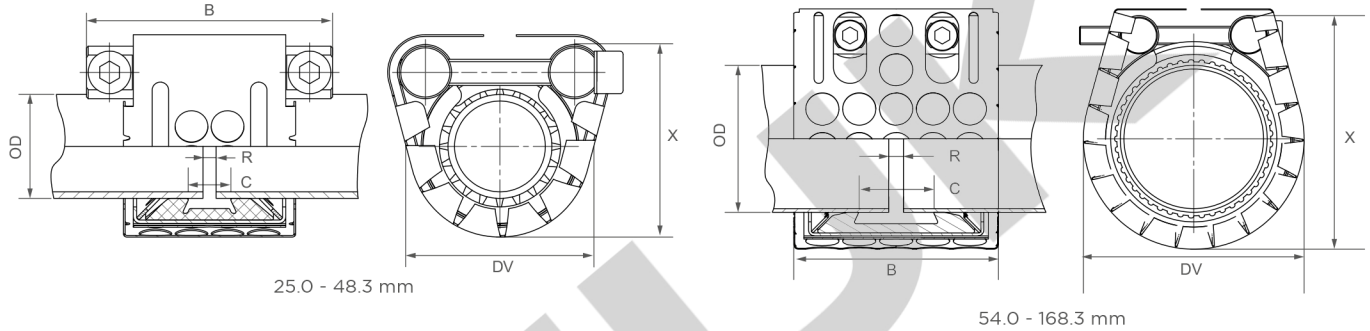

OD [mm]	Clamping range [mm]	PN [bar]	PN [bar]	B [mm]	C [mm]	DV [mm]	X [mm]	R without strip insert [mm]	R with strip insert [mm]	Torque rate [Nm]	Allen head [mm]	Thread M...
25.0	24.5 - 25.5	64	16	46.5 / 75	18	51	58	5	5 - 10	10	6	8
26.9	26.4 - 27.4	58	16	46.5 / 75	18	54	61	5	5 - 10	10	6	8
28.0	27.5 - 28.5	50	16	46.5 / 75	18	55	62	5	5 - 10	10	6	8
30.0	29.5 - 30.5	42	16	46.5 / 75	18	57	65	5	5 - 10	10	6	8
33.7	33.2 - 34.2	39	16	46.5 / 75	18	61	70	5	5 - 10	10	6	8
35.0	34.5 - 35.5	37	16	46.5 / 75	18	62	71	5	5 - 10	12	6	8
38.0	37.5 - 38.5	36	16	46.5 / 75	18	65	74	5	5 - 10	12	6	8
40.0	39.5 - 40.5	35	16	46.5 / 75	18	67	76	5	5 - 10	12	6	8
42.4	41.9 - 42.9	33	16	46.5 / 75	18	70	79	5	5 - 10	12	6	8
44.5	44.0 - 45.0	30	16	46.5 / 75	18	72	81	5	5 - 10	12	6	8
48.3	47.8 - 48.8	28	16	46.5 / 75	18	75	86	5	5 - 10	12	6	8
54.0	53.5 - 54.5	24	16	65	24	81	92	5	5 - 15	15	6	8
57.0	56.4 - 57.6	23	16	65	24	84	95	5	5 - 15	15	6	8
60.3	59.7 - 60.9	23	16	65	24	87	98	5	5 - 15	15	6	8
63.0	62.4 - 63.6	23	16	65	24	90	101	5	5 - 15	15	6	8
66.6	64.9 - 67.3	22	16	65	24	94	105	5	5 - 15	15	6	8
70.0	68.9 - 70.7	22	16	65	24	97	109	5	5 - 15	15	6	8
73.0	72.3 - 73.7	21	16	65	24	100	112	5	5 - 15	15	6	8
76.1	75.3 - 76.9	35	16	100	40	110	127	5 - 10	5 - 25	20	8	10
79.5	78.7 - 80.3	32	16	100	40	113	130	5 - 10	5 - 25	20	8	10
84.0	83.2 - 84.8	29	16	100	40	117	135	5 - 10	5 - 25	20	8	10
88.9	88.0 - 89.8	26	16	100	40	122	139	5 - 10	5 - 25	20	8	10
95.0	94.0 - 96.0	24	16	100	40	127	144	5 - 10	5 - 25	25	8	10
98.0	97.0 - 99.0	24	16	100	40	131	148	5 - 10	5 - 25	25	8	10
100.6	99.6 - 101.6	23	16	100	40	134	151	5 - 10	5 - 25	25	8	10
101.6	100.6 - 102.6	23	16	100	40	135	151	5 - 10	5 - 25	25	8	10
104.0	103.0 - 105.0	23	16	100	40	137	153	5 - 10	5 - 25	25	8	10
104.8	103.8 - 105.8	23	16	100	40	138	155	5 - 10	5 - 25	25	8	10
108.0	106.9 - 109.1	22	16	100	40	142	159	5 - 10	5 - 25	25	8	10
114.3	113.2 - 115.4	22	16	100	40	148	165	5 - 10	5 - 25	25	8	10
118.0	116.9 - 119.1	22	16	100	40	152	171	5 - 10	5 - 25	25	8	10
125.0	123.7 - 126.3	21	16	115	53	162	179	5 - 10	5 - 30	40	10	12
127.0	125.7 - 128.3	21	16	115	53	164	181	5 - 10	5 - 30	40	10	12
129.0	127.7 - 130.3	21	16	115	53	166	183	5 - 10	5 - 30	40	10	12
130.2	128.9 - 131.5	21	16	115	53	167	184	5 - 10	5 - 30	40	10	12
133.0	131.7 - 134.3	21	16	115	53	170	187	5 - 10	5 - 30	40	10	12
139.7	138.3 - 141.1	20	16	115	53	176	194	5 - 10	5 - 30	40	10	12
141.3	139.9 - 142.7	20	16	115	53	178	195	5 - 10	5 - 30	40	10	12
144.0	142.6 - 145.4	20	16	115	53	181	188	5 - 10	5 - 30	50	10	12
154.0	152.5 - 155.5	18	16	115	53	191	208	5 - 10	5 - 30	50	10	12
159.0	157.4 - 160.6	18	16	115	53	196	213	5 - 10	5 - 30	50	10	12
165.0	163.4 - 166.6	16	16	115	53	202	219	5 - 10	5 - 30	50	10	12
168.3	166.6 - 170.0	16	16	115	53	205	222	5 - 10	5 - 30	50	10	12

Components / Materials	W1	W2	W4	W5
Casing		AISI 316 L or similar		AISI 316 L or similar
Bolts		AISI 4135		A4 - 80
Bars		AISI 12L14, galvanised		AISI 316 L or similar
Anchoring rings		AISI 301		AISI 301
Strip insert (option)		AISI 316 L or similar / HDPE		AISI 316 L or similar / HDPE

<b>Sealing sleeve</b> <b>EPDM</b>	Temp.: -20°C up to +100°C Medium: all qualities of water, waste water, air, solids and chemical products
<b>Sealing sleeve</b> <b>NBR</b>	Temp.: -20°C up to +80°C Medium: water, gas, oil, fuel and other hydrocarbons
<b>Sealing sleeve</b> <b>FPM /FKM</b>	Temp.: -20°C up to +180°C Medium: ozone, oxygen, acids, gas, oil and fuel (only with strip insert)

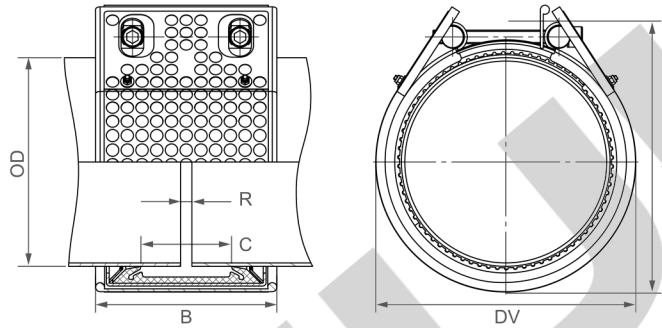

OD [mm]	Clamping range [mm]	PN [bar]	PN [bar]	B [mm]	C [mm]	DV [mm]	X [mm]	R without strip insert [mm]	R with strip insert [mm]	Torque rate [Nm]	Allen head [mm]	Thread M...
180.0	178.0 - 182.0	16	10	158	80	260	238	5 - 10	5 - 35	50	10	12
193.7	192.0 - 195.5	16	10	158	80	275	248	5 - 10	5 - 35	50	10	12
200.0	198.0 - 202.0	15	10	158	80	280	254	5 - 10	5 - 35	50	10	12
204.0	202.0 - 206.0	14	10	158	80	285	258	5 - 10	5 - 35	50	10	12
206.0	204.0 - 208.0	14	5.5	158	80	234	258	5 - 10	5 - 35	50	10	12
219.1	216.9 - 221.3	16	10	142	80	250	274	5 - 10	5 - 30	60	10	12
244.5	242.0 - 247.0	9	5.5	158	80	325	299	5 - 10	5 - 35	50	10	12
250.0	247.5 - 252.5	9	5.5	158	80	330	304	5 - 10	5 - 35	50	10	12
254.0	251.5 - 256.5	9	5.5	158	80	330	308	5 - 10	5 - 35	50	10	12
256.0	253.5 - 258.5	9	5.5	158	80	284	308	5 - 10	5 - 35	50	10	12
267.0	264.5 - 269.5	8	5	158	80	345	321	5 - 10	5 - 35	50	10	12
273.0	270.5 - 275.5	7	4	158	80	350	327	5 - 10	5 - 35	60	10	12
304.0	301.0 - 307.0	6	4	158	80	380	331	5 - 10	5 - 35	60	10	12
306.0	303.0 - 309.0	6	3	158	80	334	358	5 - 10	5 - 35	60	10	12
323.9	320.5 - 327.0	5	3	158	80	400	378	5 - 10	5 - 35	60	10	12
355.6	352.0 - 359.0	10	2.5	158	67	430	410	5 - 10	5 - 35	90	14	16
406.4	402.5 - 410.5	7	2	158	67	475	460	5 - 10	5 - 35	100	14	16