

Components / Materials	W1	W2	W4	W5
Casing				AISI 316 L / LDX 2101
Bolts				A4 - 80
Bars				AISI 316 L or similar
Anchoring rings				AISI 301
Strip insert (option)				AISI 316 L / PVDF

Sealing sleeve	Temp.:	-20°C up to +100°C
EPDM	Medium:	all qualities of water, waste water, air, solids and chemical products
Sealing sleeve	Temp.:	-20°C up to +80°C
NBR	Medium:	water, gas, oil, fuel and other hydrocarbons
Sealing sleeve	Temp.:	-20°C up to +180°C
FPM/FKM	Medium:	ozone, oxygen, acids, gas, oil and fuel (only with strip insert)

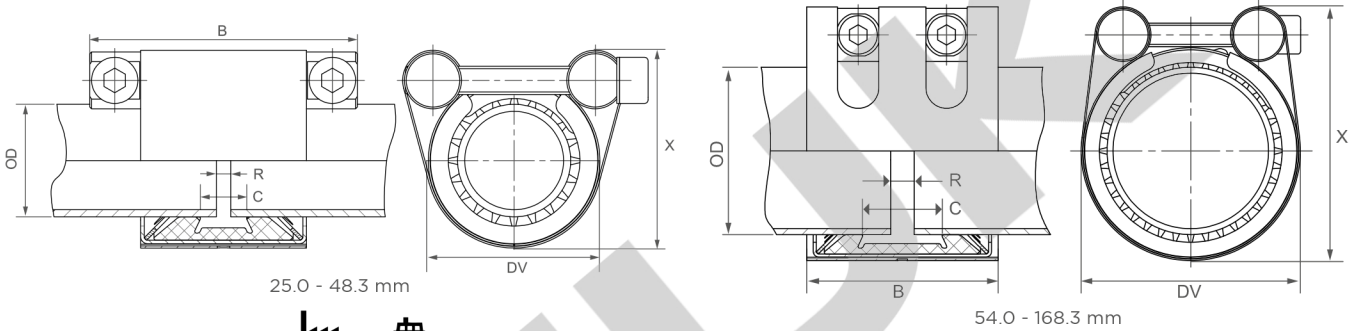

OD [mm]	Clamping range [mm]	PN [bar]	PN [bar]	B [mm]	C [mm]	DV [mm]	X [mm]	R without strip insert [mm]	R with strip insert [mm]	Torque rate [Nm]	Allen head [mm]	Thread M...
21.3	21.0 - 21.6	36	16	46	18	43	56	5	5 - 10	9	5	6
25.0	24.5 - 25.5	64	16	46.5 / 75	18	41	53	5	5 - 10	10	6	8
26.9	26.4 - 27.4	58	16	46.5 / 75	18	44	56	5	5 - 10	10	6	8
28.0	27.5 - 28.5	50	16	46.5 / 75	18	45	57	5	5 - 10	10	6	8
30.0	29.5 - 30.5	42	16	46.5 / 75	18	47	60	5	5 - 10	10	6	8
33.7	33.2 - 34.2	39	16	46.5 / 75	18	51	65	5	5 - 10	10	6	8
35.0	34.5 - 35.5	37	16	46.5 / 75	18	52	66	5	5 - 10	12	6	8
38.0	37.5 - 38.5	36	16	46.5 / 75	18	55	69	5	5 - 10	12	6	8
40.0	39.5 - 40.5	35	16	46.5 / 75	18	57	71	5	5 - 10	12	6	8
42.4	41.9 - 42.9	33	16	46.5 / 75	18	60	74	5	5 - 10	12	6	8
44.5	44.0 - 45.0	30	16	46.5 / 75	18	62	76	5	5 - 10	12	6	8
48.3	47.8 - 48.8	28	16	46.5 / 75	18	65	81	5	5 - 10	12	6	8
54.0	53.5 - 54.5	24	16	65	24	71	87	5	5 - 15	15	6	8
57.0	56.4 - 57.6	23	16	65	24	74	90	5	5 - 15	15	6	8
60.3	59.7 - 60.9	23	16	65	24	77	93	5	5 - 15	15	6	8
63.0	62.4 - 63.6	23	16	65	24	80	96	5	5 - 15	15	6	8
66.6	64.9 - 67.3	22	16	65	24	84	100	5	5 - 15	15	6	8
70.0	68.9 - 70.7	22	16	65	24	87	104	5	5 - 15	15	6	8
73.0	72.3 - 73.7	21	16	65	24	90	107	5	5 - 15	15	6	8
76.1	75.3 - 76.9	35	16	100	40	100	122	5 - 10	5 - 25	20	8	10
79.5	78.7 - 80.3	32	16	100	40	103	125	5 - 10	5 - 25	20	8	10
84.0	83.2 - 84.8	29	16	100	40	107	130	5 - 10	5 - 25	20	8	10
88.9	88.0 - 89.8	26	16	100	40	112	134	5 - 10	5 - 25	20	8	10
95.0	94.0 - 96.0	24	16	100	40	117	139	5 - 10	5 - 25	25	8	10
98.0	97.0 - 99.0	24	16	100	40	121	143	5 - 10	5 - 25	25	8	10
100.6	99.6 - 101.6	23	16	100	40	124	146	5 - 10	5 - 25	25	8	10
101.6	100.6 - 102.6	23	16	100	40	125	146	5 - 10	5 - 25	25	8	10
104.0	103.0 - 105.0	23	16	100	40	127	148	5 - 10	5 - 25	25	8	10
104.8	103.8 - 105.8	23	16	100	40	128	150	5 - 10	5 - 25	25	8	10
108.0	106.9 - 109.1	22	16	100	40	132	154	5 - 10	5 - 25	25	8	10
114.3	113.2 - 115.4	22	16	100	40	138	160	5 - 10	5 - 25	25	8	10
118.0	116.9 - 119.1	22	16	100	40	142	166	5 - 10	5 - 25	25	8	10
125.0	123.7 - 126.3	21	16	115	53	152	174	5 - 10	5 - 30	40	10	12
127.0	125.7 - 128.3	21	16	115	53	154	176	5 - 10	5 - 30	40	10	12
129.0	127.7 - 130.3	21	16	115	53	156	178	5 - 10	5 - 30	40	10	12
130.2	128.9 - 131.5	21	16	115	53	157	179	5 - 10	5 - 30	40	10	12
133.0	131.7 - 134.3	21	16	115	53	160	182	5 - 10	5 - 30	40	10	12
139.7	138.3 - 141.1	20	16	115	53	166	189	5 - 10	5 - 30	40	10	12
141.3	139.9 - 142.7	20	16	115	53	168	190	5 - 10	5 - 30	40	10	12
144.0	142.6 - 145.4	20	16	115	53	171	183	5 - 10	5 - 30	50	10	12
154.0	152.5 - 155.5	18	16	115	53	181	203	5 - 10	5 - 30	50	10	12
159.0	157.4 - 160.6	18	16	115	53	186	208	5 - 10	5 - 30	50	10	12
165.0	163.4 - 166.6	16	16	115	53	192	214	5 - 10	5 - 30	50	10	12
168.3	166.6 - 170.0	16	16	115	53	195	217	5 - 10	5 - 30	50	10	12

Components / Materials	W1	W2	W4	W5
Casing		AISI 316 L or similar		AISI 316 L or similar
Bolts		AISI 4135		A4 - 80
Bars		AISI 12L14, galvanised		AISI 316 L
Anchoring rings		AISI 301		AISI 301
Strip insert (option)		AISI 316 L or similar / HDPE		AISI 316 L or similar / HDPE

Sealing sleeve EPDM	Temp.: -20°C up to +100°C Medium: all qualities of water, waste water, air, solids and chemical products
Sealing sleeve NBR	Temp.: -20°C up to +80°C Medium: water, gas, oil, fuel and other hydrocarbons
Sealing sleeve FPM/FKM	Temp.: -20°C up to +180°C Medium: ozone, oxygen, acids, gas, oil and fuel (only with strip insert)

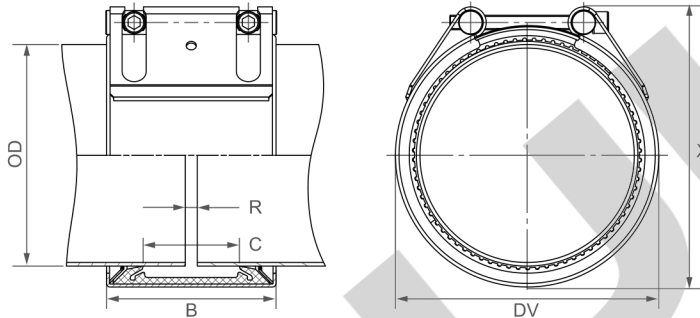

OD [mm]	Clamping range [mm]	PN [bar]	PN [bar]	B [mm]	C [mm]	DV [mm]	X [mm]	R without strip insert [mm]	R with strip insert [mm]	Torque rate [Nm]	Allen head [mm]	Thread M...
180.0	178.0 - 182.0	16	10	141	80	205	233	5 - 10	5 - 35	50	10	12
193.7	192.0 - 195.5	16	10	141	80	224	243	5 - 10	5 - 35	50	10	12
200.0	198.0 - 202.0	15	10	141	80	230	249	5 - 10	5 - 35	50	10	12
204.0	202.0 - 206.0	14	10	141	80	234	253	5 - 10	5 - 35	50	10	12
206.0	204.0 - 208.0	14	5.5	141	80	234	253	5 - 10	5 - 35	50	10	12
219.1	216.9 - 221.3	16	10	142	80	250	269	5 - 10	5 - 30	60	10	12
244.5	242.0 - 247.0	9	5.5	141	80	275	294	5 - 10	5 - 35	50	10	12
250.0	247.5 - 252.5	9	5.5	141	80	280	299	5 - 10	5 - 35	50	10	12
254.0	251.5 - 256.5	9	5.5	141	80	284	303	5 - 10	5 - 35	50	10	12
256.0	253.5 - 258.5	9	5.5	141	80	284	303	5 - 10	5 - 35	50	10	12
267.0	264.5 - 269.5	8	5	141	80	297	316	5 - 10	5 - 35	50	10	12
273.0	270.5 - 275.5	7	4	141	80	303	322	5 - 10	5 - 35	60	10	12
273.0	270.5 - 275.5	16	4	141	80	303	326	5 - 10	5 - 35	80	14	16
306.0	303.0 - 309.0	6	3	141	80	334	353	5 - 10	5 - 35	60	10	12
323.9	320.5 - 327.0	5	3	141	80	354	373	5 - 10	5 - 35	60	10	12
323.9	320.5 - 327.0	13	3	141	80	354	377	5 - 10	5 - 35	90	14	16
355.6	352.0 - 359.0	10	2.5	141	80	386	405	5 - 10	5 - 35	90	14	16
406.4	402.5 - 410.5	7	2	141	80	436	455	5 - 10	5 - 35	100	14	16
457.2	452.5 - 461.5	5	-	141	80	487	506	5 - 10	5 - 35	100	14	16
508.0	503.5 - 512.5	4	-	141	80	538	557	5 - 10	5 - 35	110	14	16
558.8	554.5 - 563.5	3	-	141	80	589	608	5 - 10	5 - 35	110	14	16
609.6	605.5 - 614.0	2	-	141	80	640	659	5 - 10	5 - 35	120	14	16
711.2	707.0 - 715.0	1	-	141	80	742	761	5 - 10	5 - 35	120	14	16

STRAUB-GRIP stepped coupling

ø 48.3 - 168.3 mm

OD		Clamping range		PN [bar]	B [wmm]	C [mm]	DV [mm]	R without strip insert [mm]	R with strip insert [mm]	Torque rate [Nm]	Allen head [mm]	Thread M...
Pipe 1 [mm]	Pipe 2 [mm]	OD 1 [mm]	OD 2 [mm]									
50.8	48.3	50.3 - 51.3	47.8 - 48.8	24	76	37	76	5	5 - 10	7.5	6	8
54.0	50.8	53.5 - 54.5	50.3 - 51.3	24	76	37	76	5 - 10	5 - 10	7.5	6	8
60.3	57.0	59.7 - 60.9	56.4 - 57.6	24	76	37	79	5 - 10	5 - 15	7.5	6	8
76.1	73.0	75.3 - 76.9	72.3 - 73.7	24	95	41	98	5 - 10	5 - 25	12	6	8
88.9	84.0	88.0 - 89.8	83.2 - 84.8	22	95	41	111	5 - 10	5 - 25	12	6	8
104.0	101.6	103.0 - 105.0	100.6 - 102.6	22	95	35	132	5 - 10	5 - 25	12	6	8
108.0	104.8	106.9 - 109.1	103.8 - 105.8	21	95	41	130	5 - 10	5 - 25	12	6	8
114.3	108.0	113.2 - 115.4	106.9 - 109.1	16	95	41	136	5 - 10	5 - 25	12	6	8
139.7	133.0	138.3 - 141.1	131.7 - 134.3	16	110	54	164	5 - 10	5 - 30	20	8	10
159.0	154.0	157.4 - 160.6	152.5 - 155.5	16	110	54	183	5 - 10	5 - 30	20	8	10
168.3	159.0	166.6 - 170.0	157.4 - 160.6	16	110	54	192	5 - 10	5 - 30	20	8	10

Typing errors may occur. Technical details are subject to change.