

Components / Materials	W1	W2	W4	W5
Casing		AISI 316 L		AISI 316 L or similar
Bolts		AISI 4135		A4 - 80
Bars		AISI 12L14, galvanised		AISI 316 L or similar
Anchoring rings		AISI 301		AISI 301
Strip insert (option)		AISI 316 L or similar / PVDF		AISI 316 L or similar / PVDF

Sealing sleeve EPDM	Temp.: -30°C up to +100°C	Medium: all qualities of water, waste water, air, solids and chemical products
Sealing sleeve NBR	Temp.: -20°C up to +80°C	Medium: water, gas, oil, fuel and other hydrocarbons

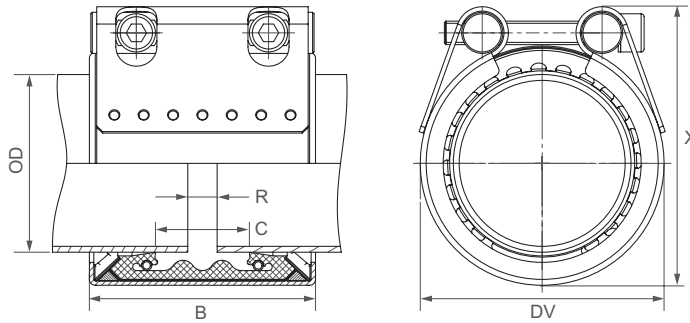

OD [mm]	Clamping range [mm]	PN [bar]	PN [bar]	B [mm]	C [mm]	DV [mm]	X [mm]	R without strip insert [mm]	R with strip insert [mm]	Torque rate [Nm]	Allen head [mm]	Thread M...
30.0	29.5 - 30.5	67	16	46/67	18	47	56	5	5	10	6	8
33.7	33.2 - 34.2	62	16	46/67	18	52	63	5	5	10	6	8
38.0	37.5 - 38.5	58	16	61	19	58	73	5	5 - 10	15	6	8
42.4	41.9 - 42.9	53	16	61	20	62	76	5	5 - 10	15	6	8
44.5	44.0 - 45.0	48	16	61	20	64	80	5	5 - 10	15	6	8
48.3	47.8 - 48.8	44	16	61	20	68	83	5	5 - 10	15	6	8
54.0	53.5 - 54.5	39	16	77	38	74	89	5	5 - 15	15	6	8
57.0	56.4 - 57.6	37	16	77	32	77	92	5 - 10	5 - 25	15	6	8
60.3	59.7 - 60.9	37	16	77	32	82	95	5 - 10	5 - 25	15	6	8
63.5	62.9 - 64.1	37	16	77	32	84	98	5 - 10	5 - 25	15	6	8
73.0	72.2 - 73.8	56	16	94	39	95	117	5 - 10	5 - 25	35	8	10
76.1	75.3 - 76.9	56	16	94	39	100	117	5 - 10	5 - 25	35	8	10
84.0	83.2 - 84.8	45	16	94	39	112	123	5 - 10	5 - 25	35	8	10
88.9	88.0 - 89.8	41	16	94	39	117	123	5 - 10	5 - 25	35	8	10
104.0	103.0 - 105.0	37	16	94	39	133	151	5 - 10	5 - 25	35	8	10
108.0	106.9 - 109.1	35	16	94	39	133	151	5 - 10	5 - 25	35	8	10
114.3	113.2 - 115.4	34	16	94	39	139	157	5 - 10	5 - 25	35	8	10
129.0	127.7 - 130.3	33	16	108	43	160	182	5 - 15	5 - 25	60	10	12
133.0	131.7 - 134.3	33	16	108	43	160	182	5 - 15	5 - 25	60	10	12
139.7	138.3 - 141.1	32	16	109	43	168	191	5 - 15	5 - 25	60	10	12
154.0	152.5 - 155.5	32	16	109	51	186	210	5 - 15	5 - 25	60	10	12
159.0	157.4 - 160.6	31	16	109	43	187	210	5 - 15	5 - 25	60	10	12
168.3	166.6 - 170.0	29	16	109	43	200	220	5 - 15	5 - 25	60	10	12
219.1	216.9 - 221.3	26	16	150	60	259	288	5 - 15	5 - 35	100	14	16

REFER TO MINIMUM WALL THICKNESS (see Technical Manual STRAUB)

Remarks:

- Follow fitting instructions
- PN () = working pressure considering the application loads
Test pressure = PN () x 1.5 (for example industry, water supply etc.)
PN () = nominal pressure, includes four times safety factor (e.g. shipbuilding)
- The pressure values are valid on radial rigid carbon steel pipes under static loads
- Strip inserts are optional accessories (see Technical Manual STRAUB)
- Additional sealing sleeves and temperature ranges on request

STRAUB-METAL-GRIP | \varnothing 180.0 - 609.6 mm

Components / Materials	W1	W2	W4	W5
Casing	AISI A738, hot-dip galvanised			
Bolts	AISI 4135			
Bars	AISI 12L14, galvanised			
Anchoring rings	AISI 301			
Strip insert (option)	AISI 316 L or similar / PVDF			
Sealing sleeve EPDM	Temp.: -20°C up to +100°C Medium: all qualities of water, waste water, air, solids and chemical products			
Sealing sleeve NBR	Temp.: -20°C up to +80°C Medium: water, gas, oil, fuel and other hydrocarbons			

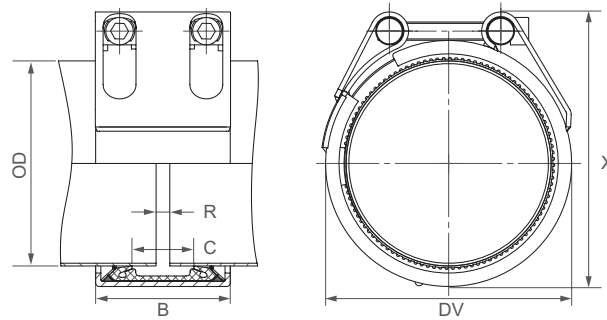

OD [mm]	Clamping range [mm]	PN [bar]	PN [bar]	B [mm]	C [mm]	DV [mm]	X [mm]	R without strip insert [mm]	R with strip insert [mm]	Torque rate [Nm]	Allen head [mm]	Thread M...
180.0	178.0 - 182.0	29	16	148	67	225	256	5 - 15	5 - 35	150	17	20
193.7	192.0 - 195.5	29	16	148	67	239	270	5 - 15	5 - 35	150	17	20
200.0	198.0 - 202.0	28	15	148	67	245	276	5 - 15	5 - 35	180	17	20
206.0	204.0 - 208.0	28	15	148	67	251	282	5 - 15	5 - 35	180	17	20
244.5	242.0 - 247.0	27	14	148	67	290	330	5 - 15	5 - 35	180	17	20
267.0	264.5 - 269.5	24	12	148	67	312	352	5 - 15	5 - 35	180	17	20
273.0	270.5 - 275.5	21	12	148	67	318	359	5 - 15	5 - 35	180	17	20
323.9	320.5 - 327.0	18	10	148	67	369	411	5 - 15	5 - 35	230	17	20
355.6	352.0 - 359.0	17	8	148	67	401	444	5 - 15	5 - 35	230	17	20
406.4	402.5 - 410.5	14	8	148	67	451	494	5 - 15	5 - 35	230	17	20
457.2	452.5 - 462.0	8	6	148	67	502	546	5 - 15	5 - 35	250	17	20
508.0	503.0 - 513.0	6	5	148	67	553	598	5 - 15	5 - 35	250	17	20
558.8	554.0 - 564.0	6	4.5	148	67	604	649	5 - 15	5 - 35	300	17	20
609.6	604.5 - 614.5	5	4	148	67	655	701	5 - 15	5 - 35	300	17	20

CONTINUOUSLY VARIABLE INTERMEDIATE SIZES FROM 180.0 TO 609.6 mm ARE AVAILABLE
REFER TO MINIMUM WALL THICKNESS (see Technical Manual STRAUB)

Remarks:

- Follow fitting instructions
- PN (🏭) = working pressure considering the application loads
Test pressure = PN (🏭) x 1.5 (for example industry, water supply etc.)
PN (🚢) = nominal pressure, includes four times safety factor (e.g. shipbuilding)
- The pressure values are valid on radial rigid carbon steel pipes under static loads
- Strip inserts are optional accessories (see Technical Manual STRAUB)
- Additional sealing sleeves and temperature ranges on request