

Components / Materials	W1	W2	W4	W5
Casing	S355MC, hot-dip galvanised	AISI 316 L or similar		AISI 316 L or similar
Bolts	AISI 4135	AISI 4135		A4 - 80
Bars	AISI 12L14, galvanised	AISI 12L14, galvanised		AISI 316 L or similar
Strip insert (option)	AISI 316 L or similar / HDPE	AISI 316 L or similar / HDPE		AISI 316 L or similar / HDPE
Sealing sleeve EPDM	Temp.: -20°C up to +100°C Medium: all qualities of water, waste water, air, solids and chemical products			
Sealing sleeve NBR	Temp.: -20°C up to +80°C Medium: water, gas, oil, fuel and other hydrocarbons			
Sealing sleeve FPM/FKM	Temp.: -20°C up to +180°C Medium: ozone, oxygen, acids, gas, oil and fuel (only with strip insert)			

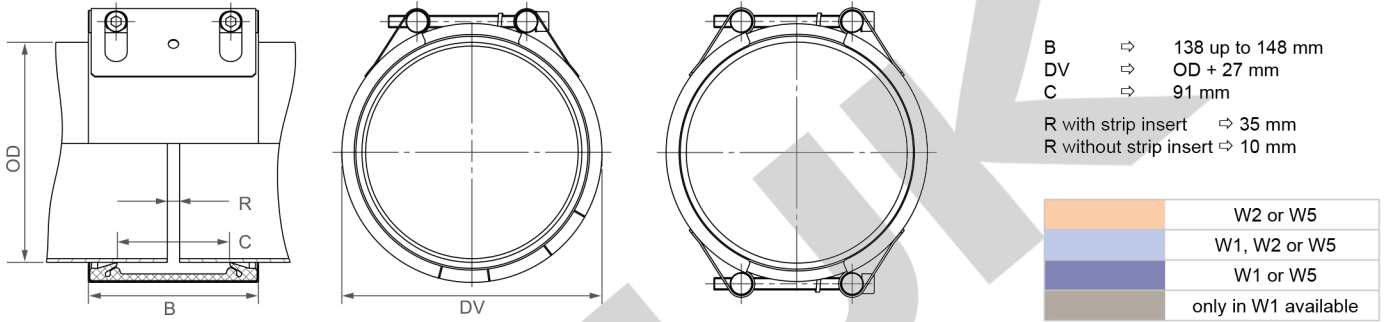

OD [mm]	Clamping range [mm]	PN						PN [bar]
		2.5	6	10	16	20	25	
172.0	170 - 174							Pressure rates according to type approval
180.0	178 - 182							
200.0	198 - 202							
219.1	217 - 222							
250.0	248 - 253							
267.0	264 - 270							
273.0	270 - 276							
304.0	301 - 307							
323.9	321 - 327							
355.6	353 - 358							
406.4	404 - 409							
457.2	454 - 460							
508.0	505 - 511							
558.8	556 - 562							
609.6	606 - 613							
711.2	708 - 715							
762.0	758 - 766							
812.8	809 - 817							
914.4	910 - 918							
1016.0	1012 - 1020							
1117.6	1114 - 1122							
1219.2	1215 - 1224							
1320.8	1316 - 1325							
1422.4	1418 - 1427							
1524.0	1519 - 1529							
1600.0	1595 - 1605							
1625.6	1621 - 1631							
1727.2	1722 - 1732							
1828.8	1824 - 1834							
1930.4	1925 - 1935							
2032.0	2027 - 2037							

Versions:

2.5	6	10	16	20	25	1 piece (slotted) [mm]	2 piece casing [mm]
x	x					≤ 1219.1	on order
x	x						> 1219.1
		x				172.0 - 355.6	on order
		x					355.6 - 457.2
		x				457.2 - 711.2	on order
		x					> 711.2
			x			≤ 219.1	on order
			x				219.1 - 1524.0
				x			172.0 - 1016.0
					x		180.0 - 762.0

Typing errors may occur. Technical details are subject to change.